



## VRLA Rechargeable Battery

# BPS100-12 (BPS100-12FR)

### FEATURES

- Maintenance free(no water topping-up required)
- No free acid(Non-spillable battery)
- Can be used in any orientation(excluding used inverted)
- Flame-arrestor is installed to ensure safety
- Carry handles for easy installation
- Absorbent Glass Mat technology for efficient gas recombination

### APPLICATION

- UPS
- Golf-Carts
- Telecom

### SPECIFICATIONS

Nominal Voltage	12V	
Nominal Capacity	20 Hour Rate (5.0A, 10.5V)	100 Ah
	10 Hour Rate (9.5A, 10.5V)	95 Ah
	5 Hour Rate (17.0A, 10.5V)	85 Ah
	1 Hour Rate (60.0A,9.3V)	60 Ah
Approx. Weight	32.7Kg(72.10lbs.)	
Terminals	B3 (Fitting M6 bolt & nut) I2 is optional	
Max. Discharge Current	800 A (5 sec.)	
Max. Charge Current	30 A	
Operating Temperature Range	Charge	0°C~40°C(32°F~104°F)
	Discharge	-20°C~50°C(-4°F~122°F)
	Storage	-20°C~40°C(-4°F~104°F)
Self Discharge	< 3% per month (25°C)	
Internal Resistance	≤ 4.5mΩ (Fully Charged )	



### CONTAINER MATERIAL

- BPS100-12:  
ABS: UL 94-HB (Dark gray color)
- BPS100-12FR:  
ABS: UL 94-V0 (Light gray color)

  ISO 9001	 ISO 14001
 MH19884 UL	 C4M20310-2474-E-16 CE
<ul style="list-style-type: none"> <li>● IEC60896-21/22</li> <li>● JIS C 8704-2</li> <li>● GB/T 19638.2</li> </ul>	

OUTER DIMENSIONS mm(inch)	Length (L)	Width (W)	Container Height (H)	Total Height (TH)
	329±2.0(12.95±0.08)	172±2.0(6.77±0.08)	216.5±2.0(8.52±0.08)	218.5±2.0(8.60±0.08)

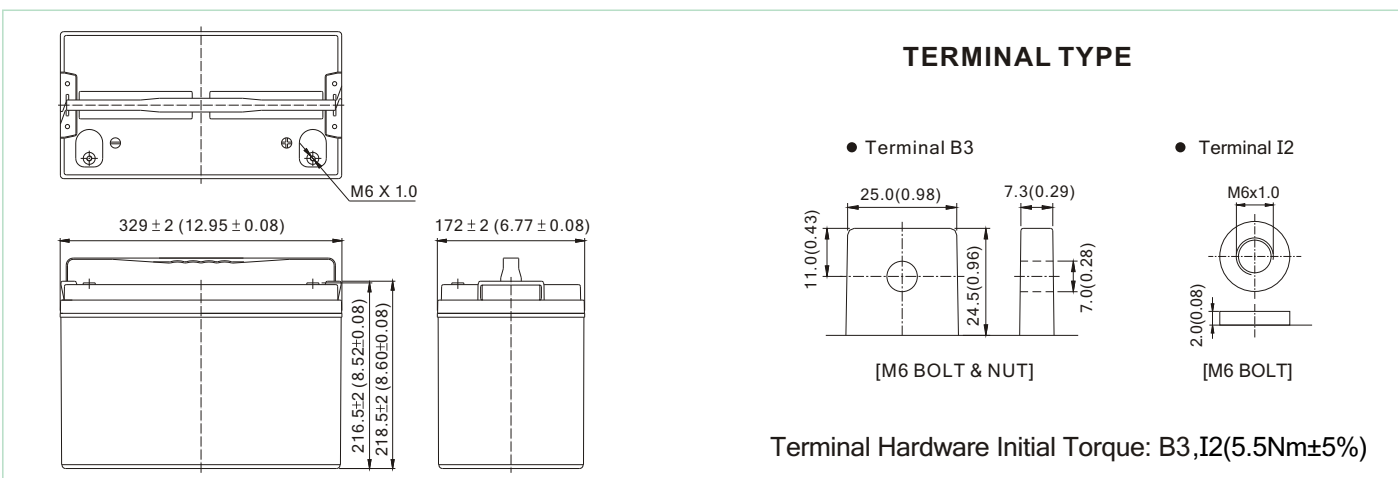

**BPS100-12 (BPS100-12FR) discharge characteristics (25°C /77°F)**

**Battery Charging Characteristics**

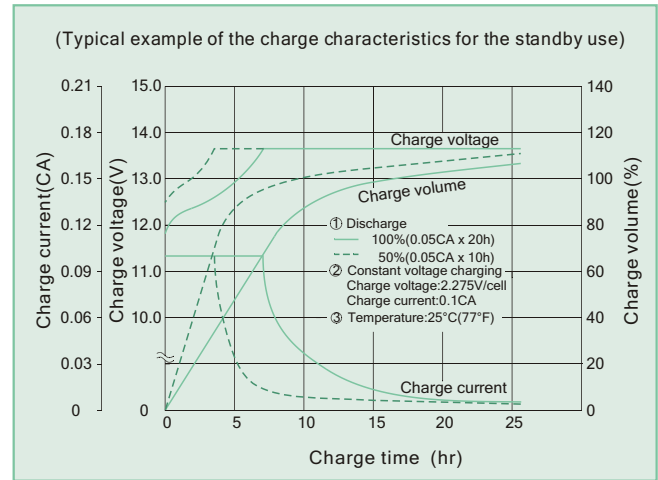
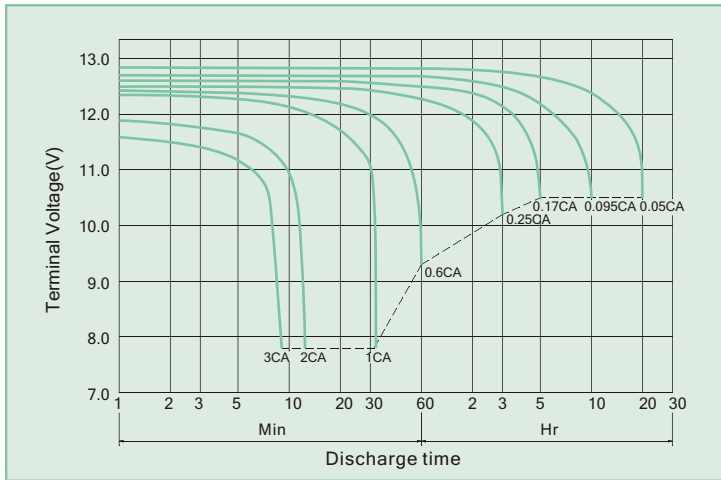

**Charging Procedure**

Application	Charging method	Charging Voltage at 25°C (V/cell)	Temperature compensation coefficient of charging voltage (mV/°C /cell)	Max. charging current (CA)	Charging time 0.1CA, 25°C (h)		Temp (°C)
					100% discharge	50% discharge	
For standby power Source	Constant voltage & Constant current charging (with current restriction)	2.25~2.30	-3	0.3	24	20	0~40 (32~104°F)
For cycle service		2.40~2.50	-4	0.3	16	10	

**Effect Of Temperature On Long Term Float Life**

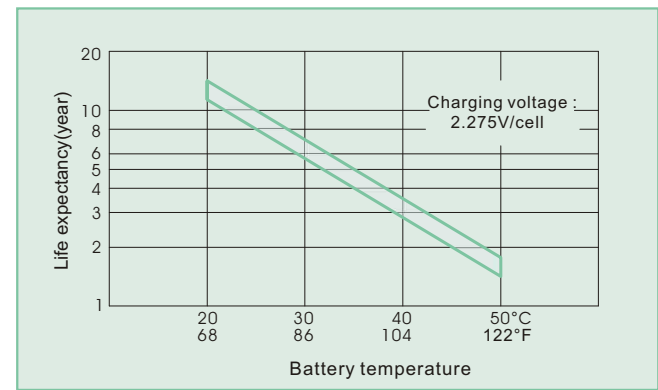

**Constant power discharge characteristics at 25 °C/77 °F Unit: W**

F.V. (V/cell) \ Discharge Time	15 Min	30 Min	1 Hr	3 Hr	5 Hr	10 Hr	20 Hr
1.80V	2065	1256	727.8	291.5	201.0	112.31	59.10
1.75V	2160	1304	749.6	297.3	204.0	114.00	60.00
1.70V	2226	1334	763.1	300.0	205.1	114.57	60.31
1.65V	2278	1353	772.3	302.1	205.8	114.91	60.48
1.60V	2323	1366	780.0	303.9	206.4	114.91	60.48

**Constant current discharge characteristics at 25 °C/77 °F Unit: A**

F.V. (V/cell) \ Discharge Time	15 Min	30 Min	1 Hr	3 Hr	5 Hr	10 Hr	20 Hr
1.80V	184.6	107.5	61.16	24.29	16.75	9.36	4.93
1.75V	193.0	111.6	62.99	24.78	17.00	9.50	5.00
1.70V	199.0	114.2	64.13	25.00	17.09	9.55	5.03
1.65V	203.6	115.8	64.90	25.17	17.15	9.58	5.04
1.60V	207.7	116.9	65.55	25.33	17.20	9.58	5.04

All data shall be changed without prior notice, BB reserves the right to explain and update the information contained hereinto.

A/2 REV. Aug. 2010

<p><b>USA:</b> B&amp;B BATTERY(USA) INC. 6415 RANDOLPH ST.COMMERCE, CA,90040 U.S.A. TEL:1-323-278-1900.1-800-278-8599 FAX:1-323-278-1268 E-Mail:sales@bb-battery.com</p> <p><b>CHINA FACTORY:</b> B. B. BATTERY CO., LTD. CHENG DONG TRIAL AREA,HUANG GANG, RAOPING, GUANG DONG,CHINA,515700 TEL:86-768-7601001-2 FAX:86-768-7601469 E-Mail:maggy@bb-battery.com</p>	<p><b>EUROPE:</b> B&amp;B BATTERY(EUROPE) B.V. SUITE 8, HAAKSBERGWEG 33, 1101 BP AMSTERDAM, THE NETHERLANDS TEL: 31-30-3200190 MOBILE: 886-933896989 E-Mail: gary@bb-battery.com</p> <p><b>HONG KONG:</b> B&amp;B BATTERY(Hong Kong) Co. TEL:852-2311-4918 FAX:852-2739-1182 E-Mail:bbhk@hkstar.com</p>	<p><b>JAPAN:</b> B&amp;B BATTERY(JAPAN) CO., LTD. 1375-11 NARAHARA-MACHI,HACHIOJI, TOKYO 193-0803,JAPAN. TEL:81-426-25-6375 FAX:81-426-25-6375 E-Mail:miyata@bb-battery.com</p> <p><b>TAIWAN:</b> B. B. BATTERY(TAIWAN) CO., LTD. TEL:886-6-502-5150 FAX:886-6-589-8087 E-Mail:kevin@bb-battery.com</p>
--	---	---