

## VRLA Rechargeable Battery

# BPS200-12 (BPS200-12FR)

### FEATURES

- Maintenance free(no water topping-up required)
- No free acid(Non-spillable battery)
- Can be used in any orientation(excluding used inverted)
- Flame-arrestor is installed to ensure safety
- Carry handles for easy installation
- Absorbent Glass Mat technology for efficient gas recombination

### APPLICATION

- UPS
- Telecom

### SPECIFICATIONS

Nominal Voltage	12V	
Nominal Capacity	20 Hour Rate (10.0A, 10.5V)	200 Ah
	10 Hour Rate (19.0A, 10.5V)	190 Ah
	5 Hour Rate (34.0A, 10.5V)	170 Ah
	1 Hour Rate (120.0A,9.6V)	120 Ah
Approx. Weight	61.5Kg(135.6lbs.)	
Terminals	B9 (Fitting M8 bolt & nut) I3 is optional	
Max. Discharge Current	800 A (5 sec.)	
Max. Charge Current	60 A	
Operating Temperature Range	Charge	0°C~40°C(32°F~104°F)
	Discharge	-20°C~50°C(-4°F~122°F)
	Storage	-20°C~40°C(-4°F~104°F)
Self Discharge	< 3% per month (25°C)	
Internal Resistance	≤ 2.5m Ω (Fully Charged )	



### CONTAINER MATERIAL

- BPS200-12:  
ABS: UL 94-HB (Dark gray color)
- BPS200-12FR:  
ABS: UL 94-V0 (Light gray color)

 ISO 9001	 ISO14001
 UL	 CE
<ul style="list-style-type: none"> <li>● IEC60896</li> <li>● GB/T 19638</li> </ul>	<ul style="list-style-type: none"> <li>● JIS C 8704</li> </ul>

OUTER DIMENSIONS mm(inch)	Length (L)	Width (W)	Container Height (H)	Total Height (TH)
	522±2.0(20.55±0.08)	202±2.0(7.95±0.08)	216±2.0(8.50±0.08)	240±2.0(9.45±0.08)

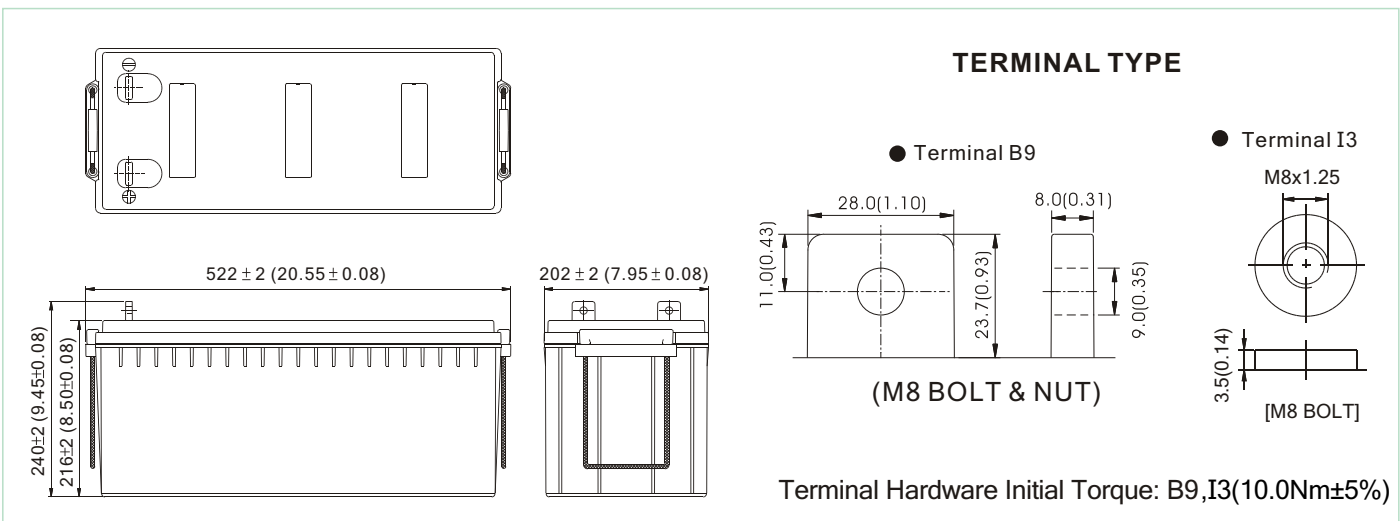

**BPS200-12 (BPS200-12FR) discharge characteristics (25°C /77°F)**

**Battery Charging Characteristics**

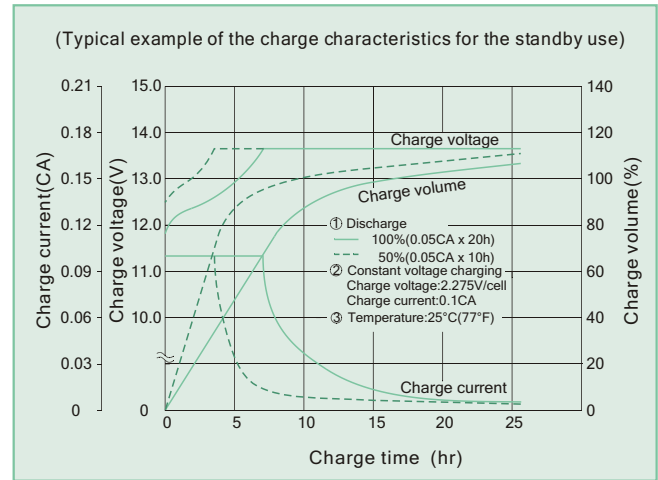
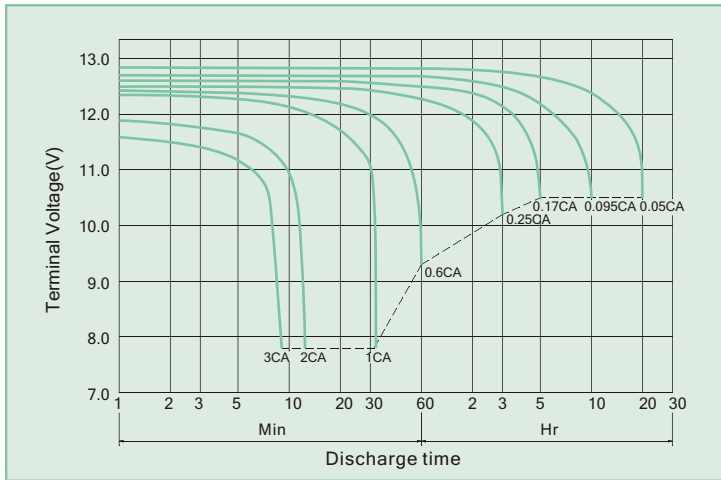

**Charging Procedure**

Application	Charging method	Charging Voltage at 25°C (V/cell)	Temperature compensation coefficient of charging voltage (mV/°C /cell)	Max. charging current (CA)	Charging time 0.1CA, 25°C (h)		Temp (°C)
					100% discharge	50% discharge	
For standby power Source	Constant voltage & Constant current charging (with current restriction)	2.25~2.30	-3	0.3	24	20	0~40 (32~104°F)
For cycle service		2.40~2.50	-4	0.3	16	10	

**Effect Of Temperature On Long Term Float Life**

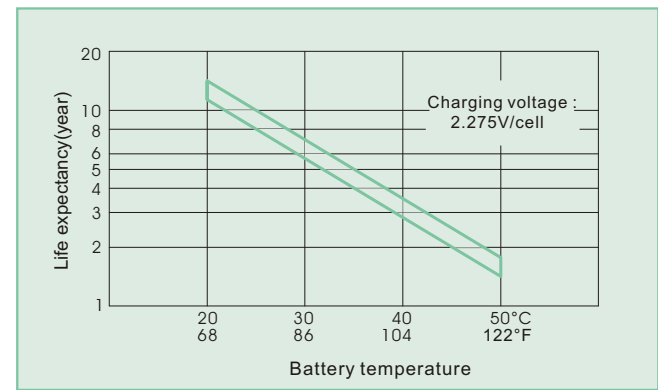

**Constant power discharge characteristics at 25 °C/77 °F Unit: W**

F.V. (V/cell) \ Discharge Time	15 Min	30 Min	1 Hr	3 Hr	5 Hr	10 Hr	20 Hr
1.80V	3724	2537	1456	582.8	402.0	224.6	118.2
1.75V	3896	2634	1499	594.6	408.0	228.0	120.0
1.70V	4016	2694	1526	600.0	410.3	229.2	120.6
1.65V	4108	2731	1545	604.3	411.7	229.7	120.9
1.60V	4190	2760	1560	607.7	412.8	229.7	120.9

**Constant current discharge characteristics at 25 °C/77 °F Unit: A**

F.V. (V/cell) \ Discharge Time	15 Min	30 Min	1 Hr	3 Hr	5 Hr	10 Hr	20 Hr
1.80V	323.8	215.0	122.3	48.57	33.50	18.71	9.85
1.75V	338.8	223.2	126.0	49.55	34.00	19.00	10.00
1.70V	349.2	228.3	128.3	50.00	34.19	19.10	10.05
1.65V	357.2	231.5	129.8	50.36	34.31	19.14	10.08
1.60V	364.4	233.9	131.1	50.64	34.40	19.14	10.08

All data shall be changed without prior notice, BB reserves the right to explain and update the information contained hereinto.

A/0 REV. Aug. 2009

<p><b>USA:</b> B&amp;B BATTERY(USA) INC. 6415 RANDOLPH ST.COMMERCE, CA,90040 U.S.A. TEL:1-323-278-1900.1-800-278-8599 FAX:1-323-278-1268 E-Mail:sales@bb-battery.com</p> <p><b>CHINA FACTORY:</b> B.B. BATTERY CO., LTD. CHENG DONG TRIAL AREA,HUANG GANG, RAOPING, GUANG DONG,CHINA,515700 TEL:86-768-7601001-2 FAX:86-768-7601469 E-Mail:maggy@bb-battery.com</p>	<p><b>EUROPE:</b> B&amp;B BATTERY(EUROPE) B.V. LAAN VAN KRONENBRUG 8, 1183AS AMSTELVEEN, THE NETHERLANDS TEL: +852-91282711 MOBILE: +852-91282711 E-Mail: dliu@bb-battery.com</p> <p><b>HONG KONG:</b> NATIONAL TRADING LTD. TEL:852-2301-3800 FAX:852-2739-1182 E-Mail:bbhk@hkstar.com</p>	<p><b>JAPAN:</b> B&amp;B BATTERY(JAPAN) CO., LTD. 1375-11 NARAHARA-MACHI,HACHIOJI, TOKYO 193-0803,JAPAN. TEL:81-426-25-6375 FAX:81-426-25-6375 E-Mail:miyata@bb-battery.com</p> <p><b>TAIWAN:</b> B.B. BATTERY(TAIWAN) CO., LTD. TEL:886-6-502-5150 FAX:886-6-589-8087 E-Mail:maggy@bb-battery.com</p>
---	---	--