

## VRLA Rechargeable Battery

# BPS4-6 (BPS4-6FR)

### FEATURES

- Maintenance free(no water topping-up required)
- No free acid(Non-spillable battery)
- Can be used in any orientation(excluding used inverted)
- Absorbent Glass Mat technology for efficient gas recombination

### APPLICATION

- UPS
- Fans
- Electronic Toy-Cars
- Emergency Lights
- Rechargeable Flashlights



### SPECIFICATIONS

Nominal Voltage	6V	
Nominal Capacity	20 Hour Rate (200mA, 5.25V)	4.0 Ah
	10 Hour Rate (380mA, 5.25V)	3.8 Ah
	5 Hour Rate (680mA, 5.25V)	3.4 Ah
	1 Hour Rate (2400mA, 4.65V)	2.4 Ah
Approx. Weight	850g(1.87lbs.)	
Terminals	T1 (Faston Tab 187) T2 is optional	
Max. Discharge Current	60 A (5 sec.)	
Max. Charge Current	1.2 A	
Operating Temperature Range	Charge	0°C~40°C(32°F~104°F)
	Discharge	-20°C~50°C(-4°F~122°F)
	Storage	-20°C~40°C(-4°F~104°F)
Self Discharge	< 3% per month (25°C)	
Internal Resistance	≤ 25m Ω (Fully Charged )	

### CONTAINER MATERIAL

- BPS4-6:  
ABS: UL 94-HB (Dark gray color)
- BPS4-6FR:  
ABS: UL 94-V0 (Light gray color)

 ISO 9001	 ISO 14001
 MH19884 UL	 C4M20310-2474-E-16 CE
<ul style="list-style-type: none"> <li>● IEC61056</li> <li>● GB/T 19639</li> </ul>	<ul style="list-style-type: none"> <li>● JIS C 8702</li> </ul>

OUTER DIMENSIONS mm(inch)	Length (L)	Width (W)	Container Height (H)	Total Height (TH)
	70±1.5(2.76±0.06)	47±1.5(1.85±0.06)	101±1.5(3.98±0.06)	106±2.0(4.17±0.08)

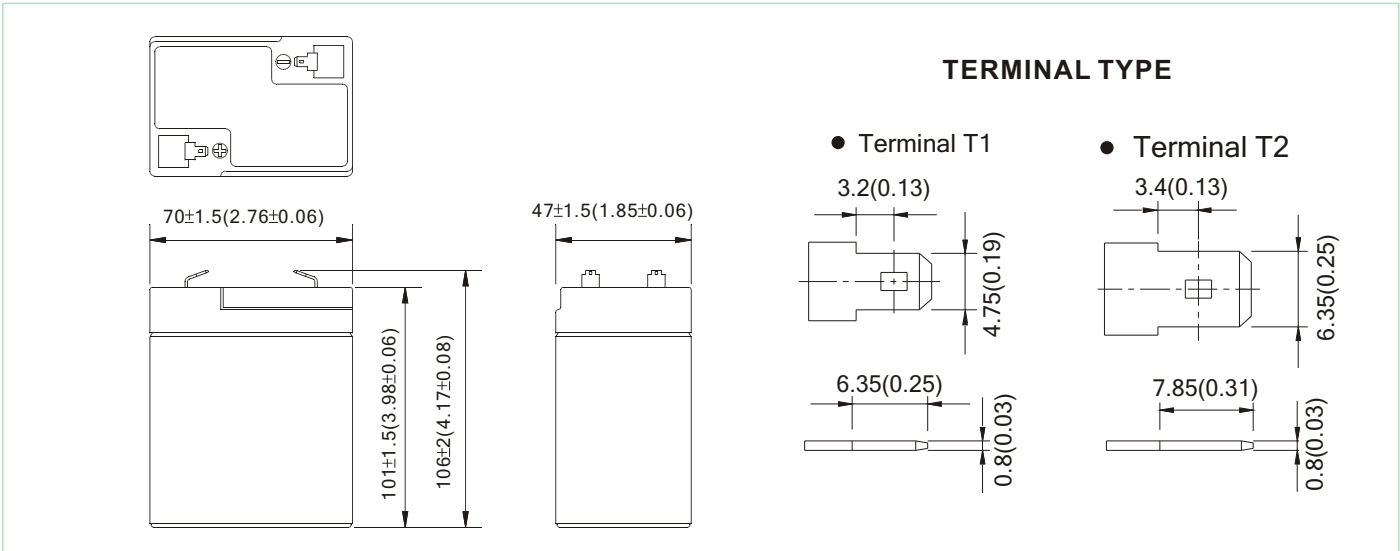

**BPS4-6 (BPS4-6FR) discharge characteristics (25°C /77°F)**

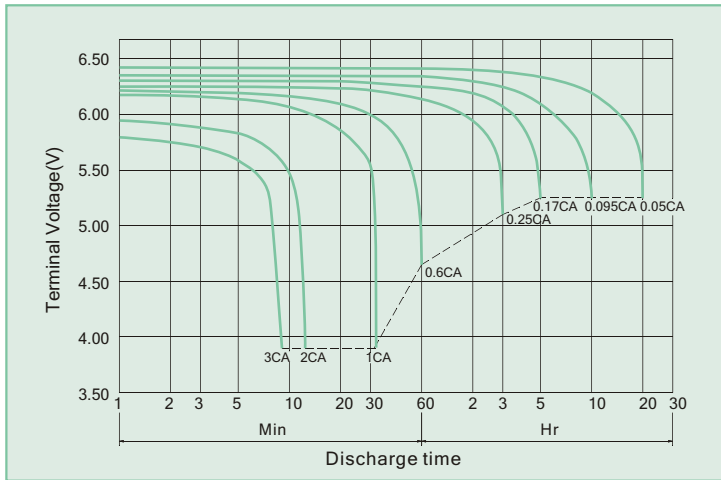

**Battery Charging Characteristics**

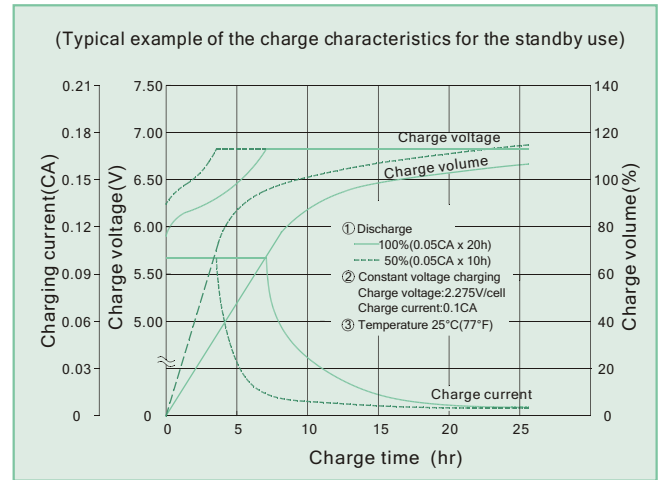

**Charging Procedure**

Application	Charging method	Charging Voltage at 25°C (V/cell)	Temperature compensation coefficient of charging voltage (mV/°C /cell)	Max. charging current (CA)	Charging time 0.1CA, 25°C (h)		Temp (°C)
					100% discharge	50% discharge	
For standby power Source	Constant voltage & Constant current charging (with current restriction)	2.25~2.30	-3	0.3	24	20	0~40 (32~104°F)
For cycle service		2.40~2.50	-4	0.3	16	10	

**Effect Of Temperature On Long Term Float Life**

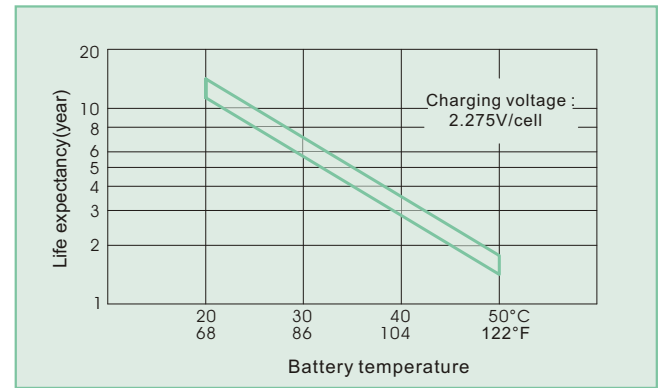

**Constant power discharge characteristics at 25 °C/77 °F Unit: W**

F.V. (V/cell) \ Discharge Time	5 Min	10 Min	15 Min	30 Min	1 Hr	3 Hr	5 Hr	10 Hr	20 Hr
1.80V	72.31	53.23	42.66	25.38	14.556	5.830	4.020	2.246	1.182
1.75V	83.70	57.67	44.62	26.34	14.993	5.946	4.080	2.280	1.200
1.70V	88.93	59.74	46.00	26.95	15.262	6.000	4.102	2.291	1.206
1.65V	92.92	61.18	47.06	27.33	15.446	6.042	4.117	2.298	1.212
1.60V	96.00	62.40	48.00	27.60	15.600	6.078	4.129	2.298	1.212

**Constant current discharge characteristics at 25 °C/77 °F Unit: A**

F.V. (V/cell) \ Discharge Time	5 Min	10 Min	15 Min	30 Min	1 Hr	3 Hr	5 Hr	10 Hr	20 Hr
1.80V	13.03	9.37	7.42	4.30	2.446	0.972	0.670	0.374	0.197
1.75V	15.36	10.15	7.76	4.47	2.520	0.991	0.680	0.380	0.200
1.70V	16.32	10.52	8.00	4.57	2.565	1.000	0.684	0.382	0.201
1.65V	17.05	10.77	8.18	4.63	2.596	1.007	0.686	0.383	0.202
1.60V	17.61	10.99	8.35	4.68	2.622	1.013	0.688	0.383	0.202

All data shall be changed without prior notice, BB reserves the right to explain and update the information contained hereinto.

A/0 REV. Aug. 2009

**USA:**  
B&B BATTERY(USA) INC.  
6415 RANDOLPH ST.COMMERCE, CA,90040 U.S.A.  
TEL:1-323-278-1900.1-800-278-8599  
FAX:1-323-278-1268  
E-Mail:sales@bb-battery.com

**CHINA FACTORY:**  
B.B. BATTERY CO., LTD.  
CHENG DONG TRIAL AREA,HUANG GANG,  
RAOPING, GUANG DONG,CHINA,515700  
TEL:86-768-7601001-2  
FAX:86-768-7601469  
E-Mail:maggy@bb-battery.com

**EUROPE:**  
B&B BATTERY(EUROPE) B.V.  
LAAN VAN KRONENBRUG 8, 1183AS  
AMSTELVEEN, THE NETHERLANDS  
TEL: +852-91282711  
MOBILE: +852-91282711  
E-Mail: dliu@bb-battery.com

**HONG KONG:**  
NATIONAL TRADING LTD.  
TEL:852-2301-3800  
FAX:852-2739-1182  
E-Mail:bbhk@hkstar.com

**JAPAN:**  
B&B BATTERY(JAPAN) CO., LTD.  
1375-11 NARAHARA-MACHI,HACHIOJI,  
TOKYO 193-0803,JAPAN.  
TEL:81-426-25-6375  
FAX:81-426-25-6375  
E-Mail:miyata@bb-battery.com

**TAIWAN:**  
B.B. BATTERY(TAIWAN) CO., LTD.  
TEL:886-6-502-5150  
FAX:886-6-589-8087  
E-Mail:maggy@bb-battery.com